

# 三相固態繼電器 3 PHASE SOLID STATE RELAY

**K3P40C90AA**  
**K3P40C100AA**  
**K3P40C125AA**

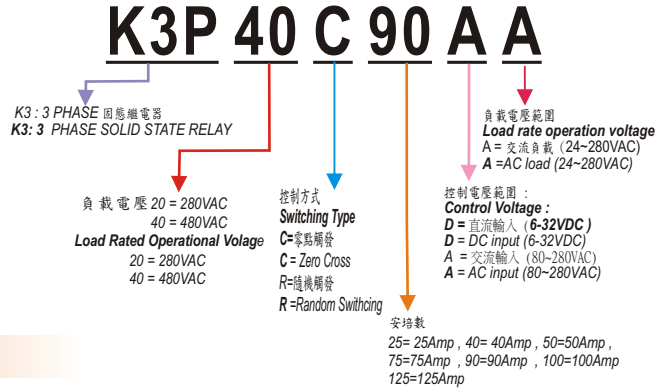

## 型號索引說明 Model No. Descriptions:



## 產品摘錄 PRODUCT SELECTON

### 輸出規格 OUTPUT SPECIFICATIONS

品名	Description	K3P40C90AA	K3P40C100AA	K3P40C125AA
最大負載電流 (25°C)	Max Load Current (25°C)	90A	100A	125A
負載電壓範圍	Operating Voltage [VAC]	48-480	48-480	48-480
破壞電壓	Maximum Transient Overvoltage [Vpk]	1200	1200	1200
洩露電流	Maximum Off-State Leakage Current @Rated Voltage [mA]	Less 10m Ams	Less 10m Ams	Less 10m Ams
最大瞬間承受電流	Maximum Surge Current [Adc] (10ms)	900A	1000A	1250A
動作壓降	Maximum On-State Voltage Drop @ Rated Current [Vdc]	1.5	1.5	1.5
瞬間電壓變化率	Maximum Off-State dV/dt [V/uSec]	1000	1000	1000

### 輸入規格 INPUT SPECIFICATIONS

品名	Description	K3P40C90AA	K3P40C100AA	K3P40C125AA
控制電壓範圍	Control Voltage Range	80-280V AC	80-280V AC	80-280V AC
最小導通電壓	Minimum Turn-on Voltage	70VAC	70VAC	70VAC
最小關斷電壓	Minimum Turn-off Voltage	10VAC	10VAC	10VAC
輸入洩漏電流	Leakage Current	15mA	15mA	15mA
最大動作時間	Maximum Turn-on Time [msec]	Less 8.3m Sec	Less 8.3m Sec	Less 8.3m Sec
最大關斷時間	Maximum Turn-off Time [msec]	Less 1/2A C cycle	Less 1/2A C cycle	Less 1/2A C cycle

### 一般規格 GENERAL SPECIFICATIONS

品名	Description	K3P40C90AA	K3P40C100AA	K3P40C125AA
輸入/輸出至外殼絕緣電壓	Dielectric Strength, Input-Output Base (50/60Hz)	4000	4000	4000
輸入/輸出絕緣電壓	Dielectric Strength, Input-Output (50/60Hz)	4000	4000	4000
絕緣電阻	Minimum Insulation Resistance	10 <sup>9</sup> ohm	10 <sup>9</sup> ohm	10 <sup>9</sup> ohm
工作溫度範圍	Ambient Operating Temperature Range	-20°C~+80°C	-20°C~+80°C	-20°C~+80°C
儲存溫度範圍	Ambient Storage Temperature Range	-40°C~+100°C	-40°C~+100°C	-40°C~+100°C
觸發方式	Switching Type	Zero Cross	Zero Cross	Zero Cross
重量	Weight (g) +/- 50g	400g	400g	400g

### GENERAL NOTES

- (1) All parameters at 25°C unless otherwise specified
- (2) Dielectric strength and insulation resistance are measured between input and output
- (3) Heat sinking require, for derating curves see next page.

等效電路圖 EQUIVALENT CIRCUIT

EQUIVALENT CIRCUIT

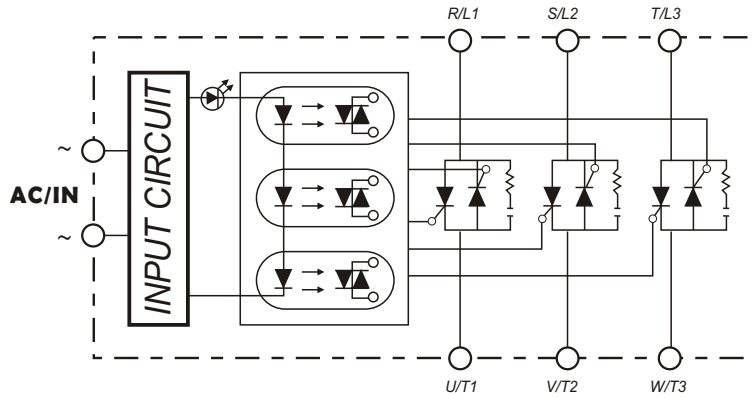

外觀尺寸圖 MECHANICAL DIMENSIONS (Unit:mm)

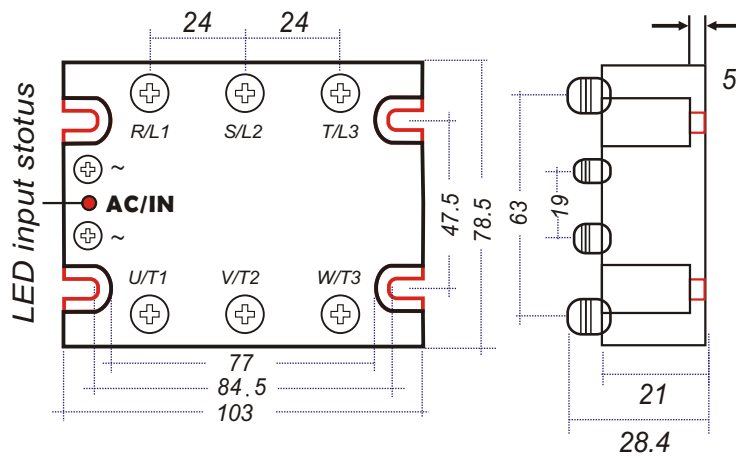

特性曲線圖 CHARACTERISTIC CURVES

Characteristics curve  
RMS On-state Current Versus Case Temperature

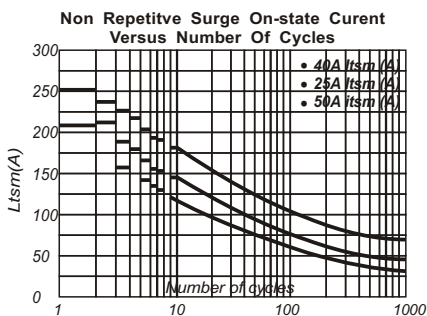
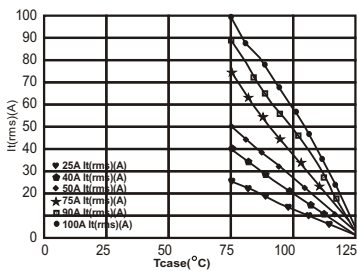

應用範例 EXAMPLE APPLICATION

